

Leonardo
2020

Accelerating technology evolution

1. PROFILE	› 6
2. EVOLUTIONARY	› 17
› Be Tomorrow - Leonardo 2030	› 18
› National Recovery and Resilience Plan	› 19
› Corporate Research Programme	› 20
› davinci-1	› 21
› Leonardo and its research	› 22
› The figures on innovation	› 23
3. AUTHORITY OVER KEY TECHNOLOGIES	› 25
› Leonardo Production System	› 26
› Leonardo as the centre of an ecosystem of companies	› 27
› Customer centricity	› 28
› Strategic Products	› 30
› International programmes	› 33
› International partnerships	› 33
4. SUSTAINABILITY IN ACTION	› 35
› 2020 ESG awards	› 36
› Priorities matrix	› 37
› Measuring sustainability	› 38
› The circular economy model	› 39
› Sustainability goals	› 40
› 2017 - 2020 ESG performance	› 41
› SDG-aligned investments	› 41

:: Innovation footprint

Presiding over strategic security technologies is central to the evolutionary path in which the human race is planning its future; a future that cannot ignore intelligent, safe and sustainable technological design to serve people, society and the planet.

The course Leonardo sets in this process represents the footprint of its innovation.

Digitisation is the enabler of this structural change in production and society. The ability to collect data and process information, to measure data using supercomputing techniques, quantitatively and qualitatively interpreting the complexity of interactions between industrial activities and natural phenomena, is a fundamental step towards bringing together progress, competitiveness and sustainability.

For this reason, Leonardo's financial report integrates economic and financial data with indicators of sustainability and innovation, on the basis of the goals of the UN Agenda 2030, in order to assess their actual implementation and prospects in the short, medium and long term. The process is driven by a model of governance that supports reporting.

It represents a specific commitment to stakeholders: a clear and articulate tool for understanding, which also involves them personally in a number of sessions for discussion and evaluation.



Over the next 10 years we will have the opportunity to establish a new social pact, also involving the ecosystem and global redistribution of wealth, health, knowledge and security. This is where the challenges of the future lie.

Profile

2020 REVENUES
€bil. **13.4**

2020 PORTFOLIO
€bil. **35.5**

2020 ORDERS
€bil. **13.8**

2020 EBITA
€mil. **938**

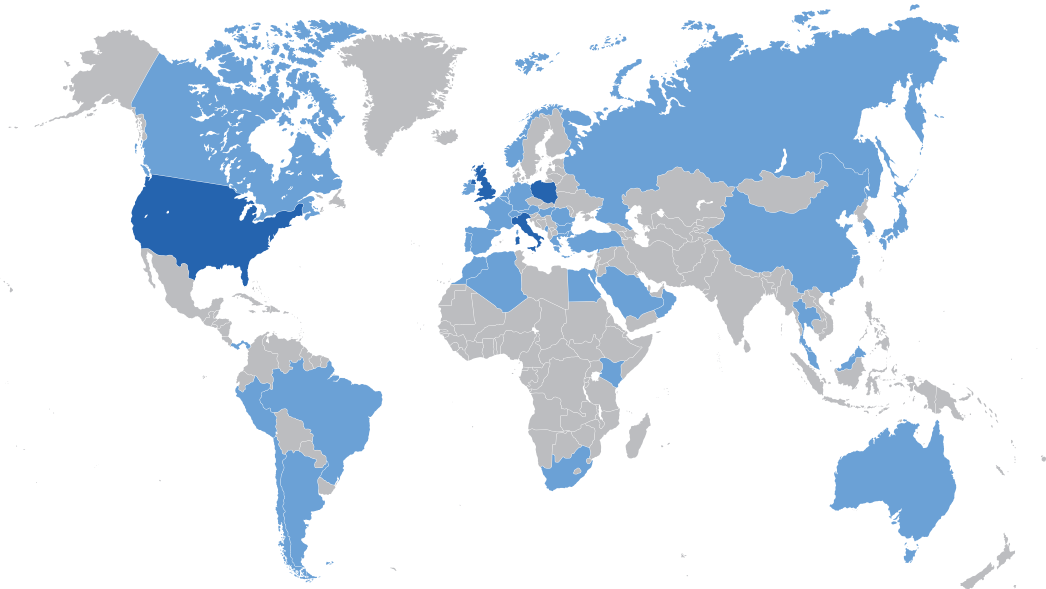

KEY COMMERCIAL PERFORMANCE INDICATORS

- > 32 TH-73As for the US Navy
- > 31 NH-90s for the German Navy
- > 15 AW169s for the Italian Army
- > 6 AW119s for the Brazilian Federal Traffic Police
- > New AESA radar generation for RAF Eurofighters

RESEARCH AND DEVELOPMENT

€mil. **1,646**

2nd PLACE IN EUROPE
4th PLACE IN THE WORLD

Investments in R&D in the AD&S sector

DOMESTIC MARKETS: Italy United Kingdom United States Poland

2020 PEOPLE
49,882

2020 SITES IN THE WORLD
103

2020 COMMERCIAL PRESENCE
150 COUNTRIES

REVENUES BY GEOGRAPHICAL AREA

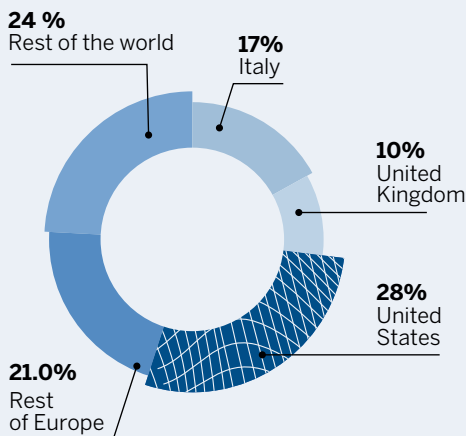

SHAREHOLDERS

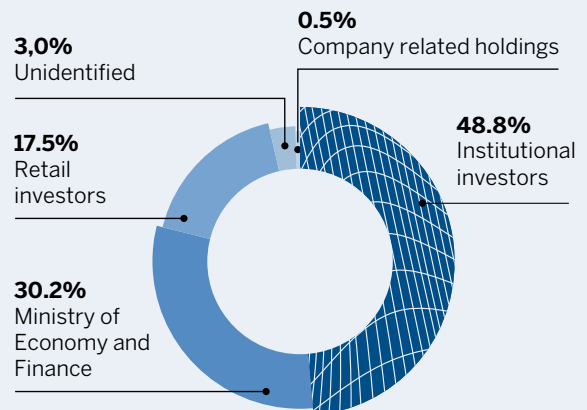

∴ Strategic Programmes

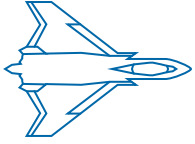

TEMPEST

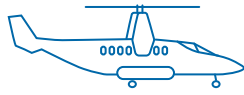

NEXT GENERATION
CIVIL TILTROTOR

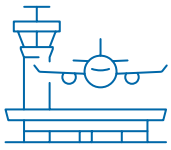

SESAR



EUROPEAN
MALE RPAS

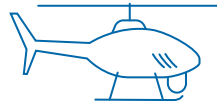

OCEAN2020

∴ Ecosystem of alliances

Shareholdings and joint ventures

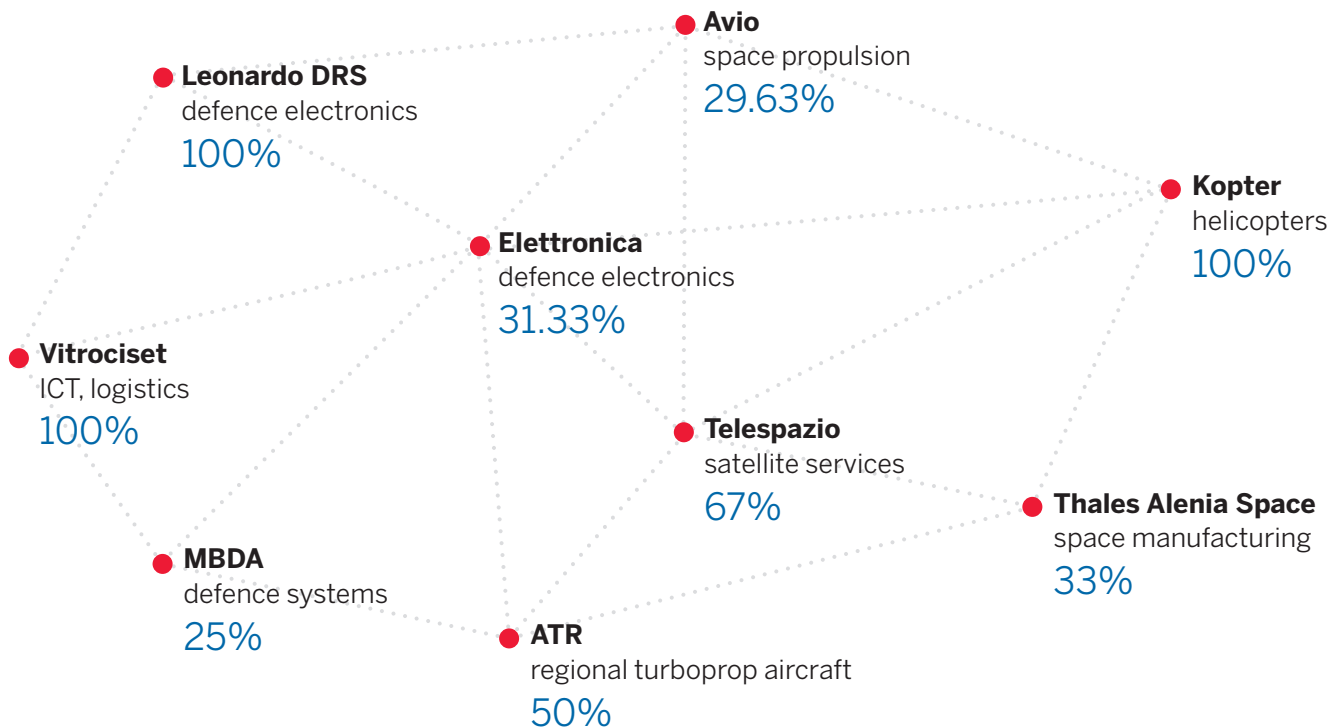

∴ Sustainable business model

∴ CAPITAL

PEOPLE AND SKILLS

- › 49,882 employees
- › approx. 8,800 people in R&D and engineering

FINANCIAL RESOURCES

- › € 1.6 bil. in R&D
- › € 8.9 bil. in purchases of goods and services
- › € 8.5 bil. net invested capital

TECHNOLOGY AND INTELLECTUAL PROPERTY

- › 6.1 petaflops of computing power
- › 27.1 petabytes of storage capacity
- › 10 Leonardo Labs

INDUSTRIAL ASSETS

- › 103 main sites and plants
- › approx. € 300 mil. investments in tangible assets

RELATIONSHIPS AND PARTNERSHIPS

- › approx. 70 universities and research centres
- › approx. 11,000 suppliers

ENERGY AND NATURAL RESOURCES

- › 100% electricity from renewable sources in Italy and the UK
- › 52% of waste recovered

∴ RESULTS AND IMPACTS

PEOPLE



- › 3,222 new hires, 43% hold a STEM degree, 41% under 30 and 23% women
- › approx. 800,000 hours of training delivered to employees
- › approx. 780 training opportunities activated with the educational system
- › approx. 41% reduction of injury rate

year 2020

PLANET



- › -8% intensity of water withdrawals
- › -8% intensity of waste produced
- › -3% intensity of energy consumption
- › 28,770 tons of CO₂ avoided through the use of virtual training systems

year 2020

PROSPERITY



- › approx. 50% SDG-aligned investments
- › 124,000 employed and €bil. 10.5 of direct, indirect and induced added value generated in Italy (2019 figures)
- › approx. 250 operators use Leonardo helicopters for emergency medical services

year 2020



∴ Priorities matrix

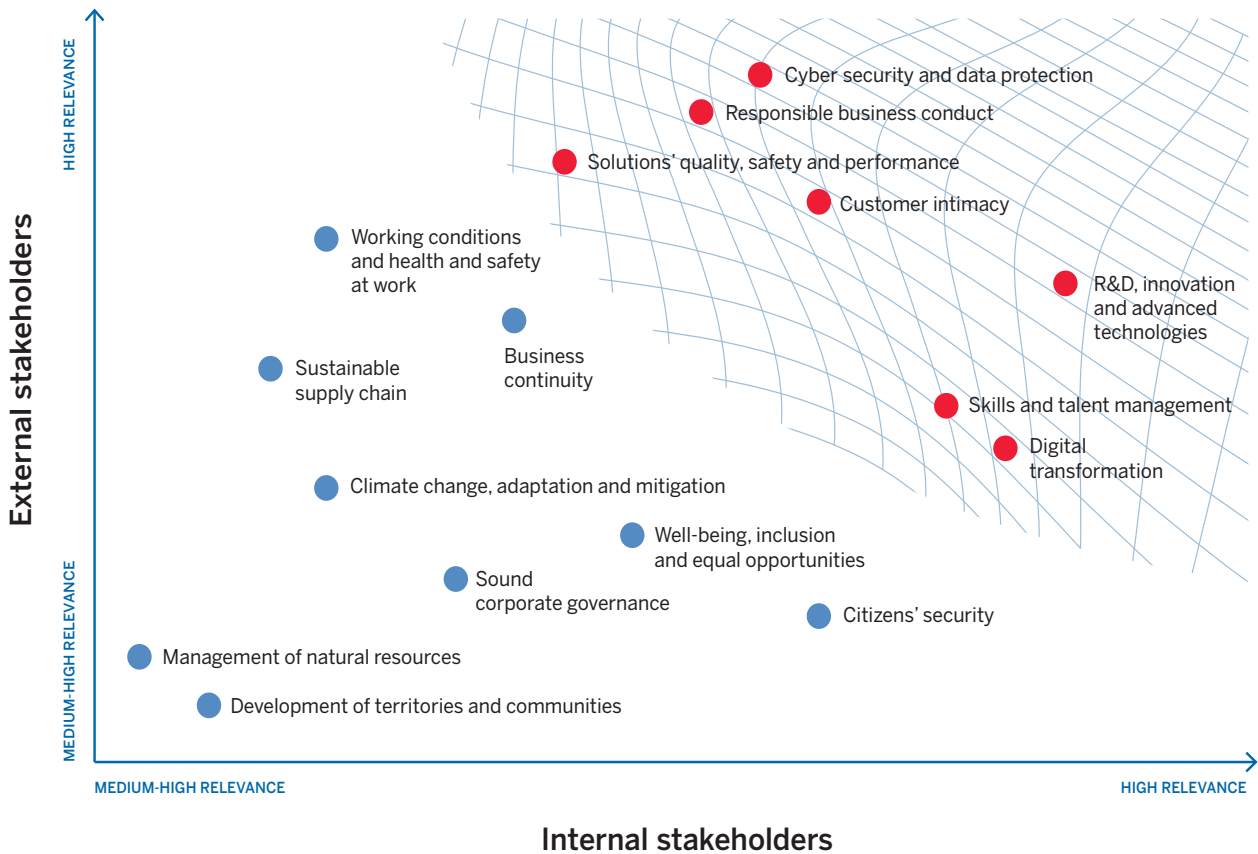

∴ ESG AWARDS



Ranked first in the Aerospace & Defence sector in the Dow Jones Sustainability Indices (DJSI), for the second year in a row. Leonardo has been included in the DJSI for 11 years in a row.



Recognised UN Global Compact LEAD for its commitment to the world's biggest corporate sustainability initiative.



In the CDP 2020 Climate-A List, among 8 Italian companies and 2 in the A&D sector.



Included in the Bloomberg Gender-Equality Index



Ranked in A band in the Defence Companies Index on Anti-Corruption and Corporate Transparency (DCI) of Transparency International.



Obtained the SEAL (Sustainability, Environmental Achievement & Leadership) Business Award honouring the 50 most sustainable companies in the world.

People

EMPLOYEES WORLDWIDE (2020)

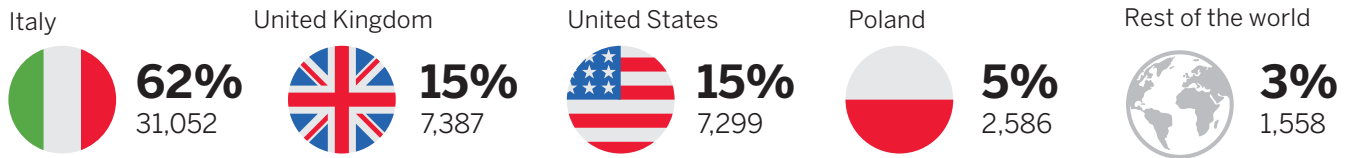

EMPLOYEES BY GENDER AND AGE GROUP



HUMAN CAPITAL EVOLUTION INDICATORS

(2020 data compared to 2017)

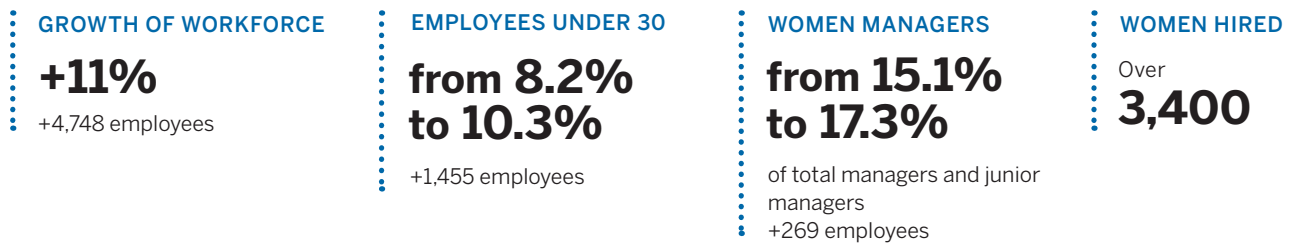

- Best Employer of Choice among the top 20 companies in Italy
- Among the companies included in Bloomberg's Gender Equality Index
- Military Friendly Employer and Best for Vets Award in the United States
- Investors in People (IiP), Investor in Young People (IiYP) and We invest in WellBeing (IIP's) in the United Kingdom

Training

LOVE FOR LEARNING: INVESTING IN SKILLS

Leonardo has redesigned its training offerings to enable all resources to keep their professional skills up to date. With the LOVE FOR LEARNING initiative launched in July 2020, Leonardo became the first Italian company to extend to all its personnel, worldwide, Coursera's extensive training services as one of the world's leading MOOC (Massive Online Open Courses) platforms, offering a catalogue of some 4,500 courses produced by the world's top universities, accessible from home and office, from a desktop or mobile device. The university level of the courses enables all participants to obtain the corresponding certificates.

62%
of employees hold a STEM degree

43%
of new hires in 2020 hold a STEM degree

About **800,000** hours of training delivered

LEONARDO ENGINEERING TRANSFORMATION

The first in Italy and in the world in the AD&S (Aerospace, Defence & Security) sector to use a cutting-edge platform applying AI to internal reskilling and new talent search processes, with a STEM-based upskilling map.

SCIENTIFIC CITIZENSHIP

The promotion of scientific citizenship is an integral part of the strategy of Leonardo - which aims to be a reference point for STEM culture in the countries where it operates - for strengthening skills and the innovation pipeline.

More than **37,000** students reached with university Career Days and job fairs in Italy and the United States

1,653 hours of teaching by Leonardo employees in 5 Italian Technical High Schools (ITS)

More than **780** training opportunities activated with the educational system

46 Italian institutes supported with the crowdfunding project "Leonardo for the School"

Leadership in Aerospace, Defence and Security



HELICOPTERS

Research, design, development and production of helicopters for civil - where it is the world's leading manufacturer - and defence applications. Leonardo's helicopters, from the 1.8 ton single-engine to the 16 ton three-engine, fulfil missions of public utility, public order, off-shore, search and rescue, helicopter rescue and defence on land and sea. To respond to the needs of future vertical mobility, Leonardo is committed to researching innovative technologies and platforms, such as the tiltrotor and the optionally piloted or unmanned helicopter.

2020 ORDERS: €bil. 4.5
2020 PORTFOLIO: €bil. 12.4

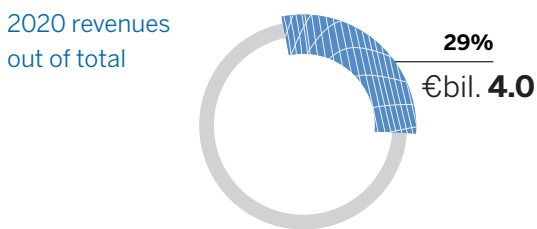

MARKET 2020-2029: €bil. 156
CAGR 2020-2029: 2.0%

HIGHLIGHTS

- Over **4,300** helicopters operating in more than **130** countries
- 156** helicopter simulators and training devices sold

DEFENCE ELECTRONICS & SECURITY

Design, development and production of complex integrated systems, subsystems, equipment and components for applications in the land, sea, air, space and cyber domains.

To ensure global security, design, development and production of integrated systems and solutions for physical and logical security, digital transformation and secure communications.

2020 ORDERS: €bil. 7.4
2020 PORTFOLIO: €bil. 13.4

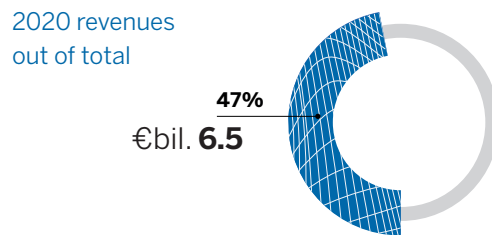

MARKET 2020-2029: €bil. 3,234
CAGR 2020-2029: 6.4%

HIGHLIGHTS

- 5,000** networks and **70,000** users protected by cyber services in **130** countries
- 900** air defence and surveillance radars sold in **58** countries
- 200** airports in **110** countries use ATC systems
- 20** ports in **7** countries use vessel traffic control systems

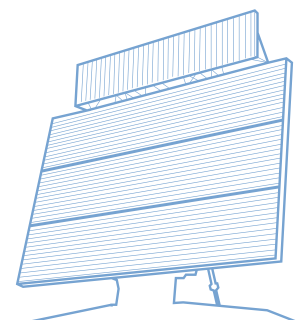

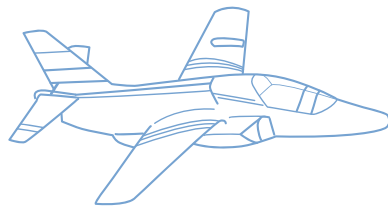

✦ AERONAUTICS

Design, development and production of aircraft for training, tactical transport, defence and surveillance, ranging from basic training to complex defence and peace enforcement operations; from tactical transport to humanitarian support; from command & control to intelligence, surveillance and reconnaissance. Participation in the Eurofighter, European MALE, F-35/JSF and Tempest programmes.

Specific expertise in the manufacture and assembly of large composite and traditional metal structural components, including the design of aerostructures for some of the most important commercial aircraft, such as class-leading ATR regional transport aircraft.

2020 ORDERS
€bil. **2.6**

2020 PORTFOLIO
€bil. **10.7**

2020 revenues
out of total

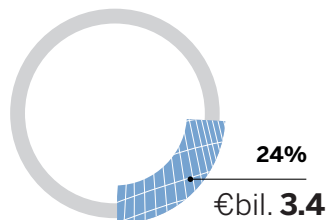

MARKET 2020-2029
CIVIL
€bil. **2,080**

CAGR 2020-2029
CIVIL
2.8%

MARKET 2020-2029
DEFENCE
€bil. **815**

CAGR 2020-2029
DEFENCE
4.4%

HIGHLIGHTS

- ✦ 86 M-346s ordered
- ✦ Over 1700 ATRs ordered by 200 airlines in more than 100 countries worldwide
- ✦ 87 C-27J aircraft ordered by 15 countries

✦ SPACE

Design and manufacture of electro-optical instruments, robotics and equipment for space programmes.

Through Telespazio, telecommunications, navigation and positioning, Earth observation and geoinformation services. Launch operations and putting into orbit.

Through Thales Alenia Space, design and production of orbiting infrastructure, satellites, radar sensors and subsystems.

MARKET 2020-2029

€bil. **1,312**

CAGR 2020-2029

4.3%

HIGHLIGHTS

- ✦ On board ASI's PRISMA mission is the only **hyperspectral instrument** currently in orbit, capable of performing chemical and physical analysis of elements observed on Earth
- ✦ More than **1,000,000** radar images acquired by the COSMO-SkyMed constellation of ASI and the Italian Ministry of Defence in its first 10 years of operation
- ✦ More than **40%** of the habitable volume of the International Space Station built by Thales Alenia Space

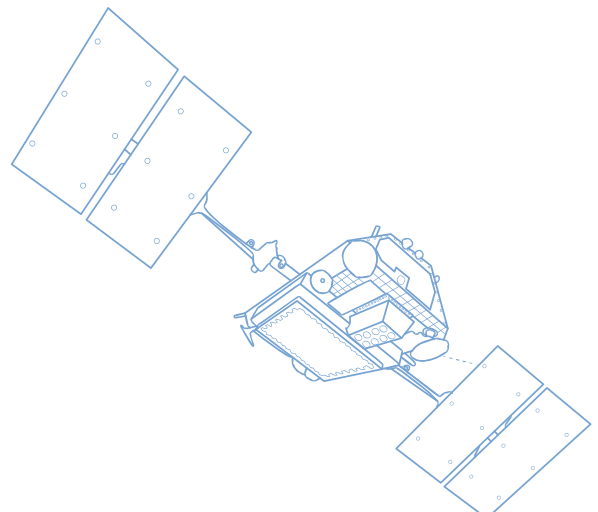

:: Key events of 2020



Launch of the Be Tomorrow - Leonardo 2030 strategic plan

Vision of the company in ten years and beyond, with parallel definition of the plan for digital transformation and the 2030 Sustainability Plan.



Launch of Leonardo Labs

Technology incubators to support Leonardo in long-term research and development of the most innovative technologies, particularly digital technologies.



Kopter acquisition

This operation strengthens our leadership in the helicopter sector, accelerating development of revolutionary technologies, new mission capabilities and increased performance.



Transparency

Ranked in A band in Transparency International's Defence Companies Index on Anti-Corruption and Corporate Transparency (DCI).



Launch of the whistleblowing platform

Launch of Leonardo's new whistleblowing platform for more effective management of reports of internal violations.



Drone contest organisation

Open Innovation project to promote the development of AI applied to unmanned systems, carried out in collaboration with six Italian universities.

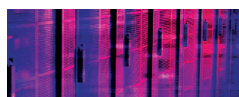

Launch of davinci-1

Leonardo's supercomputer, ranked among the top one hundred in the world for performance, with a computing power of over 5 million billion floating-point operations per second.



Business Hero

The UK Chambers of Commerce organisation awards Leonardo the Business Hero award for its contribution during the Covid-19 emergency.

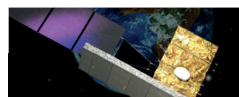

Extension of the second generation COSMO-SkyMed

Signature of a contract with the Italian Ministry of Defence and the Italian Space Agency for the doubling of the Earth observation system satellites.



Laying the cornerstone of the IFTS

Work begins on the International Flight Training School, an international benchmark for advanced military pilot training, in collaboration with the Italian Air Force.



Launching the X-2030 platform

A secure city management solution concentrating technologies such as AI and the Cloud and processing them by providing a snapshot of the situation, collecting huge amounts of data also from open sources (web, social media, satellite data).

∴ Innovation timeline

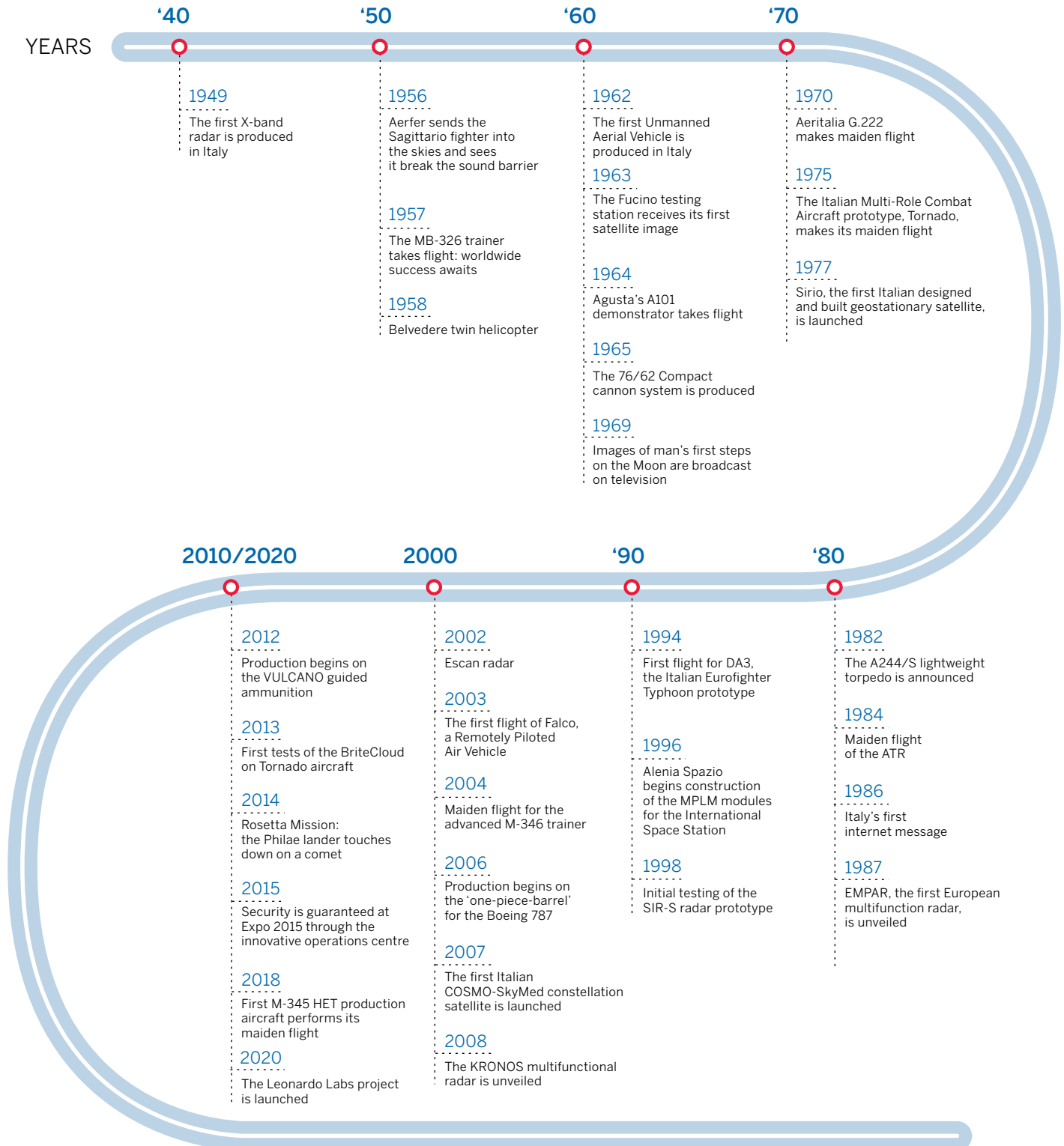

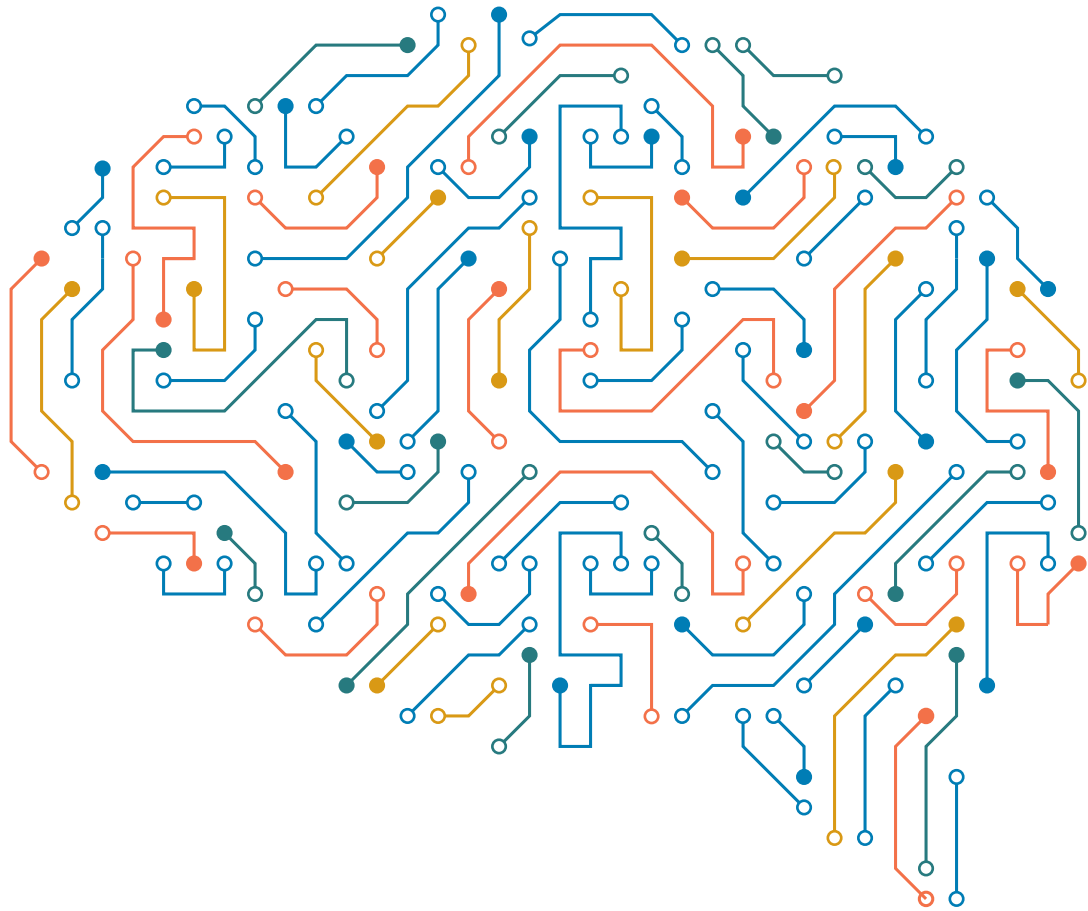

∴ Evolutionary

Planning for the future requires knowledge, expertise and the ability to control the practical implications of our actions over time. The most important resource for meeting this kind of challenge is people. People who, with their know-how, actively promote the kind of open, multidisciplinary environment essential for guiding innovation, technology and society over time.

In pursuit of this transformation, Leonardo Labs were set up in 2020: technology incubators designed to direct Leonardo's research and development over the long term with the aim of anticipating innovation cycles, advancing the frontier of technology.

The digital revolution is a key part of this transformation. Digitisation means processing huge amounts of data, being able to perform calculations at very high speeds, extracting new information and generating knowledge. This is why we have built one of the world's most powerful supercomputers, the davinci-1.

A concrete example of digitisation is the digital twin, which virtually models a product to permit accurate predictive assessments in even the most critical situations. Its potential is based on the possibility of collecting data with diffuse sensors and then processing the data through interaction with multiple sources to gain a greater understanding of the complexity of the phenomena being modelled. The result is an information *continuum* that teaches itself, constantly learning to improve with feedback that reviews processes at every stage, increasing its efficiency, offering clear advantages in terms of time, costs and environmental impact.

Digitisation is the direction in which Leonardo's technology is evolving towards the future, integrating new functions that allow applications in new areas, with important benefits also in terms of sustainability.

Digital transformation is radically changing us and the world we live in. This represents an important opportunity to reprogramme our society on the basis of a deeper understanding of the complexity that surrounds us, with assessments that also take long-term effects into account.

Be Tomorrow - Leonardo 2030 is the strategic plan with which the company has expressed a clear vision of its path for the next ten years and beyond: to strengthen and transform the business in order to grow, accelerate the process of innovation and increase long-term competitiveness in a logic of sustainability. The goal is to develop new skills, in both the civil and military domain, to respond to the challenges posed by the complexity of the digital age: interdependence, interrelation and rapid evolution.

∴ **TARGET FOR 2030**

1. Solid



- › Attractive to investors and highly dependable
- › Profitable and with a solid ability to generate cash

2. Global



- › A world leader in our top sectors: helicopters, simulation and training
- › Number one in Europe in Defence Electronics and unmanned aerial systems

3. Driver of Innovation



- › Fully digitalised in all processes, production and offering
- › The engine of an innovative eco-system along interconnected technological lines
- › Point of reference for 'green' innovation

- › Key player in collaborative international aviation programmes
- › Reference partner of institutions in safety & security programmes
- › Global player in Space

∴ **GUIDELINES FOR DEVELOPMENT**

1. Strengthen our “core”

- › Evolve from product supplier to global partner
- › Strengthen our sales network
- › Optimise the product portfolio built around our distinctive capabilities

2. Transform to grow

- › Invest in people and know-how
- › Become a fully digitalised company in all key processes
- › Promote a quality, innovative, integrate, resilient supply chain
- › Promote an offering based on an excellent customer service

3. Master the new

- › Accelerate the process of innovation and boost investment in research
- › Create corporate laboratories to develop technologies with highly innovative content, cutting across all our business sectors
- › Make the most of intellectual property rights, adopting an open approach to the market and to innovative start-ups
- › Establish a high-tech fund to enhance the IP produced by Leonardo Labs while investing in innovative start-ups
- › Strong focus on Intelligent Autonomous Systems
- › Enhance our positioning in the Space sector as a domain for application of new technologies and key assets to reinforce our offering of high value-added services

∴ National Recovery and Resilience Plan

Under Italy's PNRR - National Recovery and Resilience Plan - Leonardo is putting its expertise at the service of the country to guide it through the process of digital and green transition. Leonardo's Cloud Computing platform, integrated in the National Cloud, becomes a primary tool for the modernisation and revitalisation of the country.

∴ 5 REFERENCE CLUSTERS



Global Monitoring

Continuous monitoring and securing of critical infrastructure



Smart Cities

Increasing the safety and resilience of cities by promoting sustainable mobility



Digital PA

Facilitating the delivery of easily usable, efficient and secure digital public services



Digital Logistics

Contributing to the development of connected, automated and secure multimodal logistics



Health

Contributing to the development of an efficient and interconnected health system

∴ ENABLERS



Private/Hybrid
Cloud



High
Performance
Computing



Artificial
Intelligence
Algorithms



Predictive
Simulation
Capability



Tools Supporting
Decision-making



Command &
Control



Cyber-security

Corporate Research Programme

10 Leonardo Labs

Technology hubs dedicated to long-term research and development of the most innovative technologies. An international network made up of centres in Italy and abroad - also in collaboration with industrial partners and research centres - connected to the global research ecosystem.

8 Areas of research

- › Digital twins and advanced simulation
- › Artificial Intelligence and Green Computing
- › Big Data
- › HPC/CLOUD
- › Unmanned and Robotic Technologies
- › Quantum Technologies
- › Platform hybridisation and electrification
- › Materials technologies

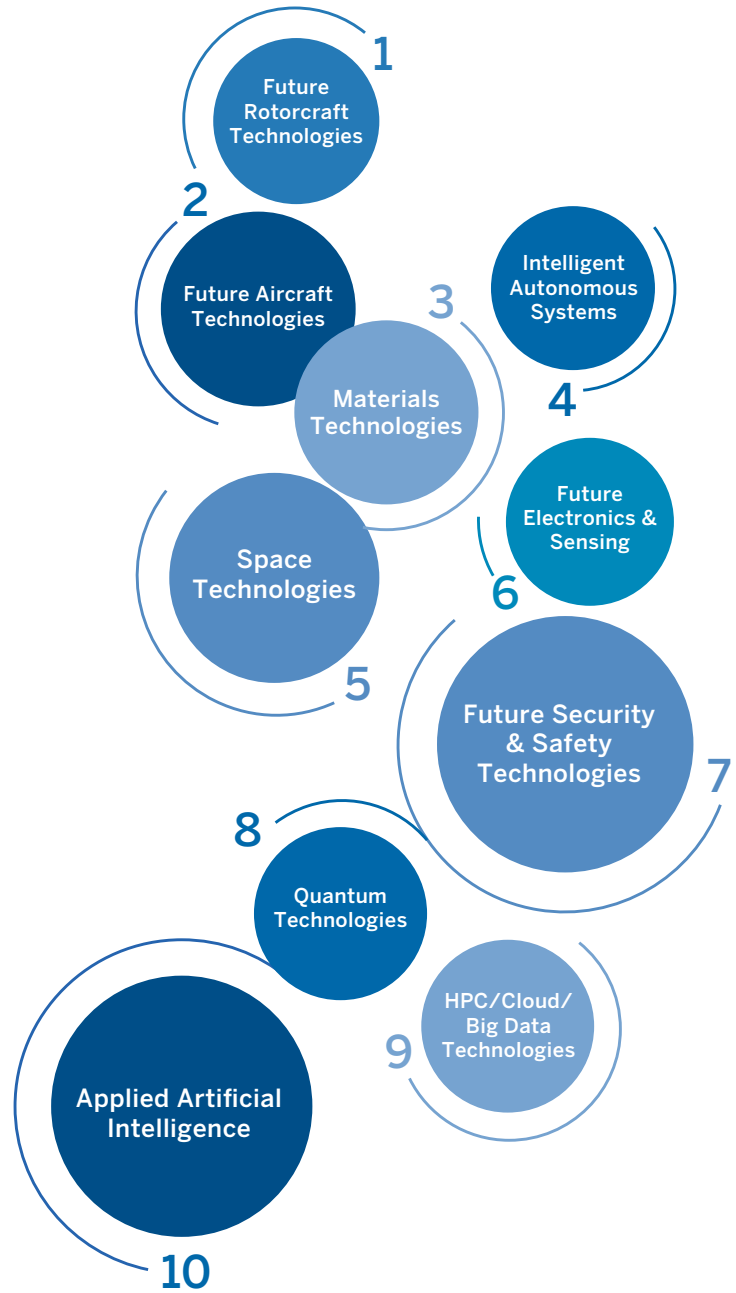

DIGITAL TWIN IN LEONARDO

- › Multiphysics and multi-scale modelling through advanced numerical simulations of complex systems, fully using the HPC davinci-1 infrastructure and GPUs (Graphics Processing Unit) parallel computing – a calculation performed in parallel on highly scalable hardware platforms
- › Development of a big data analytics infrastructure, Internet of Things and specific artificial intelligence algorithms to analyse and define strategies for predictive maintenance
- › Creation of an automated framework for product design activities, to complete the transition to computational engineering and reduce time to market
- › Advanced and parallel simulation to develop virtual experiments with the aim of minimising physical tests during certification activities
- › Data-driven systems based on numerical simulation data, on-board sensors and manufacturing cycle, to create advanced virtual models and accelerate advanced prototyping activities thermoplastics and RF shielding.



••• davinci-1

The davinci-1 supercomputer is Leonardo's answer for driving technological transformation towards the digitisation of industry. Its architecture is designed to combine the capabilities of the cloud with supercomputing; to create an integrated cloud computing platform combining flexibility with computing power.

In this way, Leonardo makes computing resources accessible in a transparent way, allowing, for example, development of particularly complex new AI models and speeding up their training process and real-time execution through parallel execution. Cloud-computing will also allow complex, high-fidelity numerical models to be run directly in virtual operating scenarios, significantly reducing the time it takes to design and test our systems.

150
supercomputing
units

Storage capacity
20
petabytes

Total power greater
than
5
petaflops

Leonardo and its research



14
fields of
technology

INTELLECTUAL PROPERTY

The type of patents developed are mainly oriented toward dual use of technologies in sectors adjacent to AD&S (Aerospace, Defence & Security), assisting small and medium-sized enterprises in the development of their products and supporting emerging start-ups.

Patents by key technology

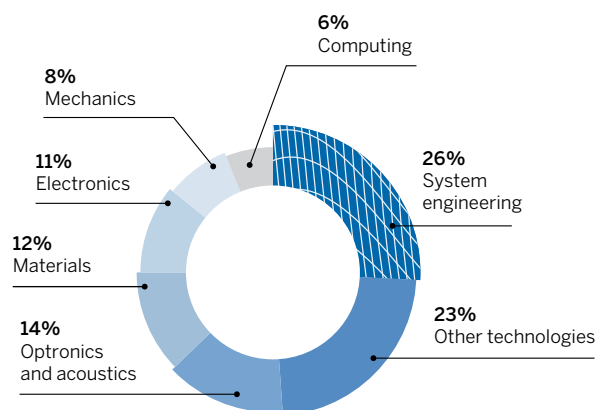

Patents by sector

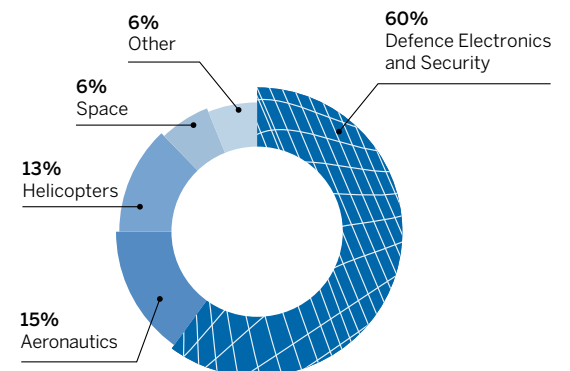

:: The figures on innovation



1.6
billion euros invested in
R&D in 2020



5%
Compound annual
growth rate (CAGR) of
patent portfolio over last
10 years



More than
400
technologies make up
Leonardo's technology
portfolio



More than
70
universities and
research centres
around the world with
whom we collaborate



Around
9,000
people involved
in research and
development
activities

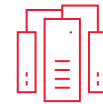

6.1 petaflops
of computing power
27.1 petabytes
of storage capacity

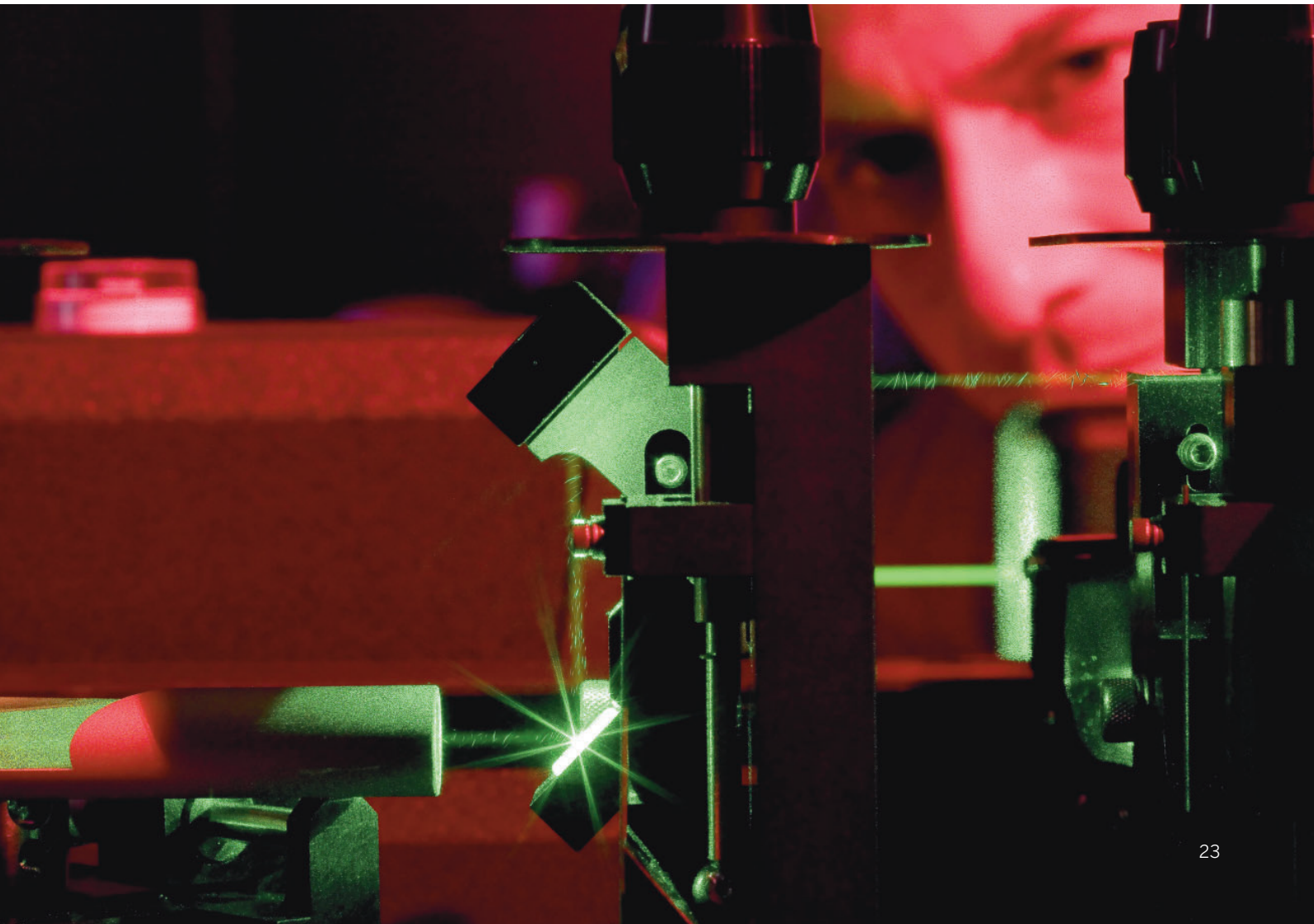

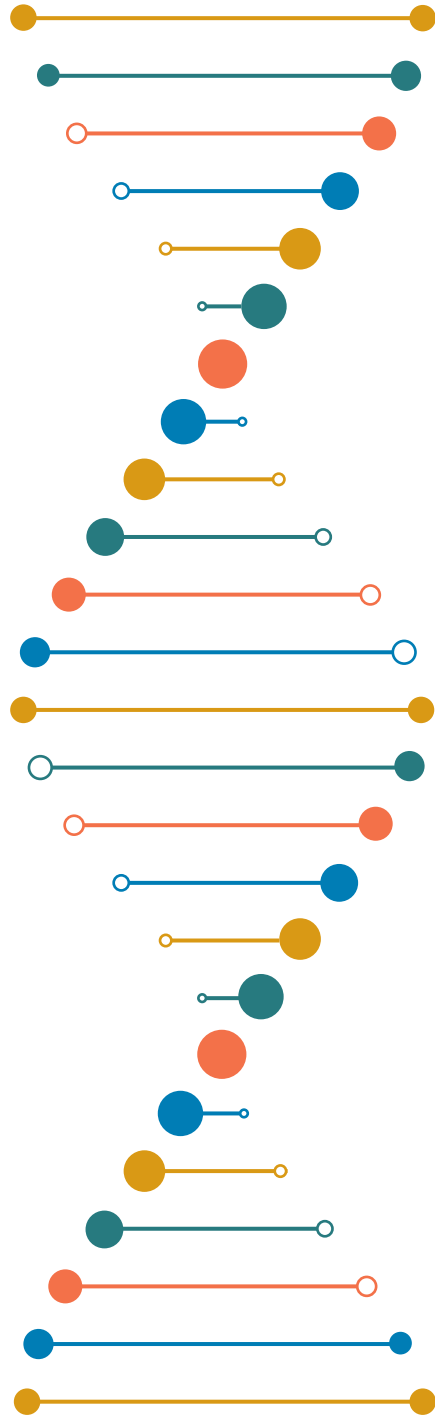

∴ Authority over key technologies

Leonardo's most important value lies in its ability to create strategic technologies for aerospace, defence and security, guiding their evolution: an articulated industrial ecosystem specialising in areas such as helicopters, electronic and autonomous systems, aircraft, space, new materials, robotics, artificial intelligence and supercomputing. These are sectors in which the company is pushing forward the frontiers of innovation, to increase its competitiveness and design and shape the solutions that will characterise the Leonardo of tomorrow, identifying the directions of future evolution.

Paths that become cutting-edge products and services in a variety of fields in which Leonardo boasts internationally recognised excellence. From the AW139 multi-role helicopter, a world best-seller in its class, to the Falco Xplorer unmanned system used for surveillance missions. From the M-346 trainer, one of the most advanced jet aircraft for training military pilots, to the COSMO-SkyMed constellation, the first Earth observation satellite system designed for dual purposes.

Distinctive traits that allow us to play a leading role in international strategic programmes in the defence sector (Eurofighter, F-35, NH90, NATO AGS, FREMM, Tempest and Male 2025), aviation (CleanSky, SESAR) and in space (Galileo, Copernicus, COSMO-SkyMed, ExoMars and Artemis). And to play a primary role in public-private partnerships with institutions, defence and international organisations such as the European Commission, ASI, ESA, NATO and NASA, in order to define new concepts - in terms of protection and surveillance of allied nations - and explore innovative frontiers, from artificial intelligence to digital networks.

Driving technological progress is our sustainability project for society.

Leonardo Production System

The LPS programme is an advanced production system that improves the process of transformation from raw materials to finished products through standardisation of processes and development of people's professional skills.

In line with the Be Tomorrow - Leonardo 2030 strategic plan, the LPS 4.0 programme was launched to digitise the LPS methodology and tools for accelerating execution and results.

Baseline 2019

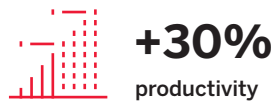

Leonardo as the centre of an ecosystem of companies

Leonardo's activity develops an interconnected and innovation-driven supply chain. A system that translates into a supply chain present in 77 countries and made up of 11,000 companies - over 4,000 in Italy alone - with an order value of around 9 billion euros, 4 billion of which is generated in Italy.

LOCAL SUPPLY CHAINS: SMEs AS A PERCENTAGE OF THE TOTAL



Italy 86%



United Kingdom 71%



United States 71%



Poland 87%

PURCHASES BY TYPE

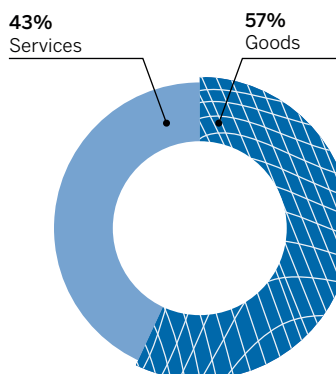

PURCHASES BY COUNTRY

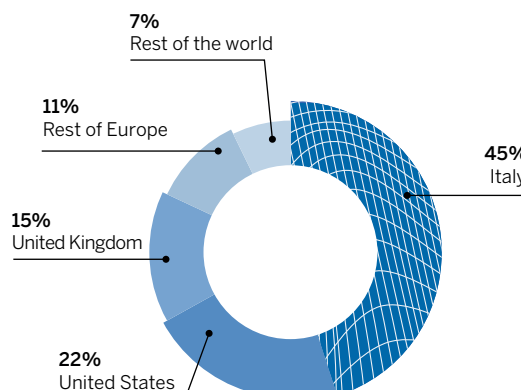

€bil. **8.9**

of purchases of goods and services

63%

incidence of purchases on revenues

82%

of purchases related to domestic markets, with a supply chain of more than 7,000 SMEs

In Italy, where related industries generate €10.5 billion in added value, Leonardo is at the heart of an ecosystem employing over 124,000 people and generating a value of production of around €22 billion, including direct, indirect and related industries.

LEAP2020 PROGRAMME

Leonardo Empowering Advanced Partnerships 2020 (LEAP2020) is a new supplier management model, which aims to create the best conditions for enhancing partners' capabilities and technological excellence.

- › More than 1,300 suppliers analysed
- › 200 eligible for partnerships
- › More than 100 involved in development projects and managerial and specialist training programmes, commercial partnership agreements, financial agreements, support for technology transfer and digital transformation

:: Customer centricity

:: TRAINING SERVICES PROVIDER

Integrated training services for civil and military pilots, operators and technical personnel, through a global network of training centres with extensive use of simulation systems and LVC (Live-Virtual- Constructive) learning environments, to ensure the highest levels of safety.

:: MRO (MAINTENANCE REPAIR AND OVERHAUL) AND ADVANCED/FULL SERVICE OFFERINGS

MRO and advanced / full services, powered by a global network of assistance and logistics centres to guarantee support for platforms and systems throughout their life cycle. A portfolio of advanced turnkey services supported by proprietary digital tools to ensure operations, mission effectiveness, cost and warehouse optimisation.

:: AN INNOVATIVE AND COMPREHENSIVE GLOBAL PARTNER

Services supporting the operational capabilities of partners in all types of missions and ensuring their long-term industrial technological growth.

:: TECHNICAL SERVICES PROVIDER

Technical and logistical services, 24/7 assistance, easy access through the Leonardo Customer Portal: site management, installation and setup, in-service data acquisition, configuration and obsolescence management, technical publications and info-logistics services.

26%

of total 2020 revenues from Customer Support, Service and Training

220

people involved in the first edition of the MOVE (Mindset, Objectives, Vision, Enhancement) course

More than

2,800

people in the Customer Support, Services & Training all over the world

900

people involved in the Data Driven Mindset pilot course, aimed at making data management an added value for the customer



∴ Strategic Products

∴ HELICOPTERS

AW139

A multi-role helicopter capable of carrying out any type of mission: search and rescue, security, offshore, private and executive transport.

AW101

The most advanced and powerful multi-role aircraft available on the market today. Equipped with sophisticated avionics and mission systems, it guarantees maximum operational efficiency, thanks to its high degree of autonomy.

AW609

The first tiltrotor for civil and governmental applications. Combining the benefits of helicopters with those of airplanes.



∴ AERONAUTICS

C27-J

World benchmark for new generation medium-sized tactical turboprop transport aircraft.

M-346

Among the most advanced jet aircraft for training military pilots. Offering extensive training capabilities, long-term reliability and reduced costs in operation.

M-345

Trainer intended for the basic to advanced phases of military pilot training with the performance typical of a jet aircraft and operating costs comparable to those of high-powered turboprop trainers.

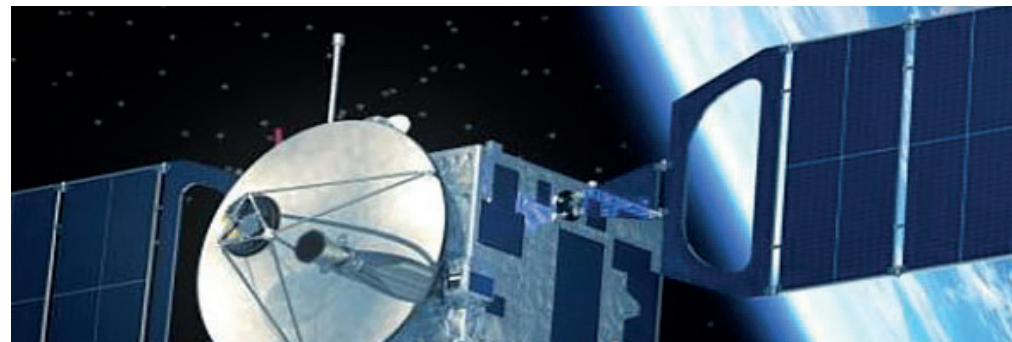

∴ SPACE

COSMO-SkyMed

Italian satellite system for Earth observation, equipped with synthetic aperture radar sensors, ensuring global coverage of the planet under all weather conditions.

SICRAL

Italian satellite system for military communications, guaranteeing interoperability of defence, public safety and civil protection networks.

Copernicus

European satellite programme for monitoring the Earth, the marine environment, the atmosphere and climate change.

Galileo

The European Union's Global Navigation Satellite System (GNSS).

DEFENCE ELECTRONICS & SECURITY

FALCO Xplorer

Unmanned system providing 24/7 surveillance under all conditions, covering a wide range of military and civil missions.

SeaSpray

AESA (Active Electronically Scanned Array) radar for surveillance with air-to-air and air-to-ground capabilities, including the detection of small targets.

KRONOS

A family of state-of-the-art, multi-function, multi-mission radars for land and naval air surveillance and defence.

ATHENA

Advanced naval theatre management system for all ship types, from patrol vessels to the largest aircraft carriers.

Miysis DIRCM (Directed InfraRed Counter Measure)

System for protecting aircraft against potential threats.

IRST (InfraRed Search & Track) systems

Family of sensors for supporting air-to-air and air-to-surface missions with long-range target discovery and tracking capability in all scenarios and modes.

Software Defined Radio

Family of radios for broadband communications, designed so that functions and features can be modified by software.

SICOTE

Territorial control system supplied to the Carabinieri, with threat prevention and analysis functions.

OTO 76/62 SR

Multi-role defence system, also installable on small ships.

Black Shark

Multi-target heavy torpedo (surface or underwater threats), usable from a variety of launch platforms (submarines, surface units, shore stations).





RH
FFA-JT-JAB-NOMI
REMOVE BEFORE
FLIGHT

∴ International programmes

TEMPEST

A next generation 'system of systems' to meet the future combat air challenges of the future.

NEXT GENERATION CIVIL TILTROTOR

Research project for development of a new generation tiltrotor, equipped with new technologies and a new aircraft architecture permitting a 50% reduction in CO₂ emissions.

EUROPEAN MALE RPAS

Medium-altitude, long-range remotely piloted aircraft for global ISTAR (Intelligence, Surveillance, Target Acquisition & Reconnaissance) missions.

SESAR

European research programme for transforming air traffic management and making it more modular, automated, interoperable and focused on the flow of flights.

OCEAN2020

EU-funded research project focusing on naval surveillance technologies to strengthen European defence capabilities.

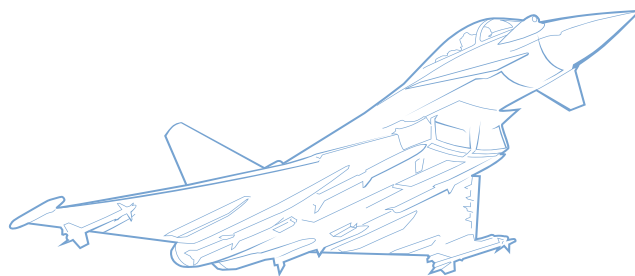

∴ International partnerships

EUROFIGHTER

Multi-role fighter born from a collaborative project of the defence industries of Italy, the UK, Germany and Spain.

NATO AGS

NATO system for territorial surveillance, based on radar technology and implemented with the contribution of 15 allied countries.

F-35

A new generation network-enabled fighter with stealth features.

FREMM

The most important naval military programme ever established at European level, carried out in cooperation between France and Italy.

NH90

Europe's largest helicopter programme, developed to meet the needs of military operators worldwide, with dedicated mission systems for land and naval operations.

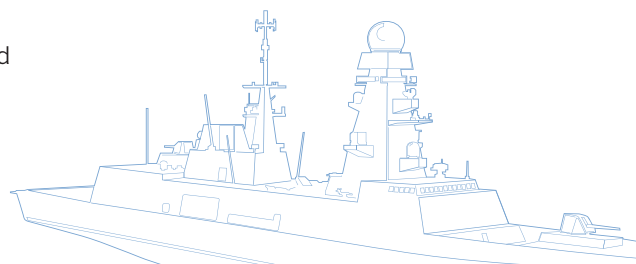

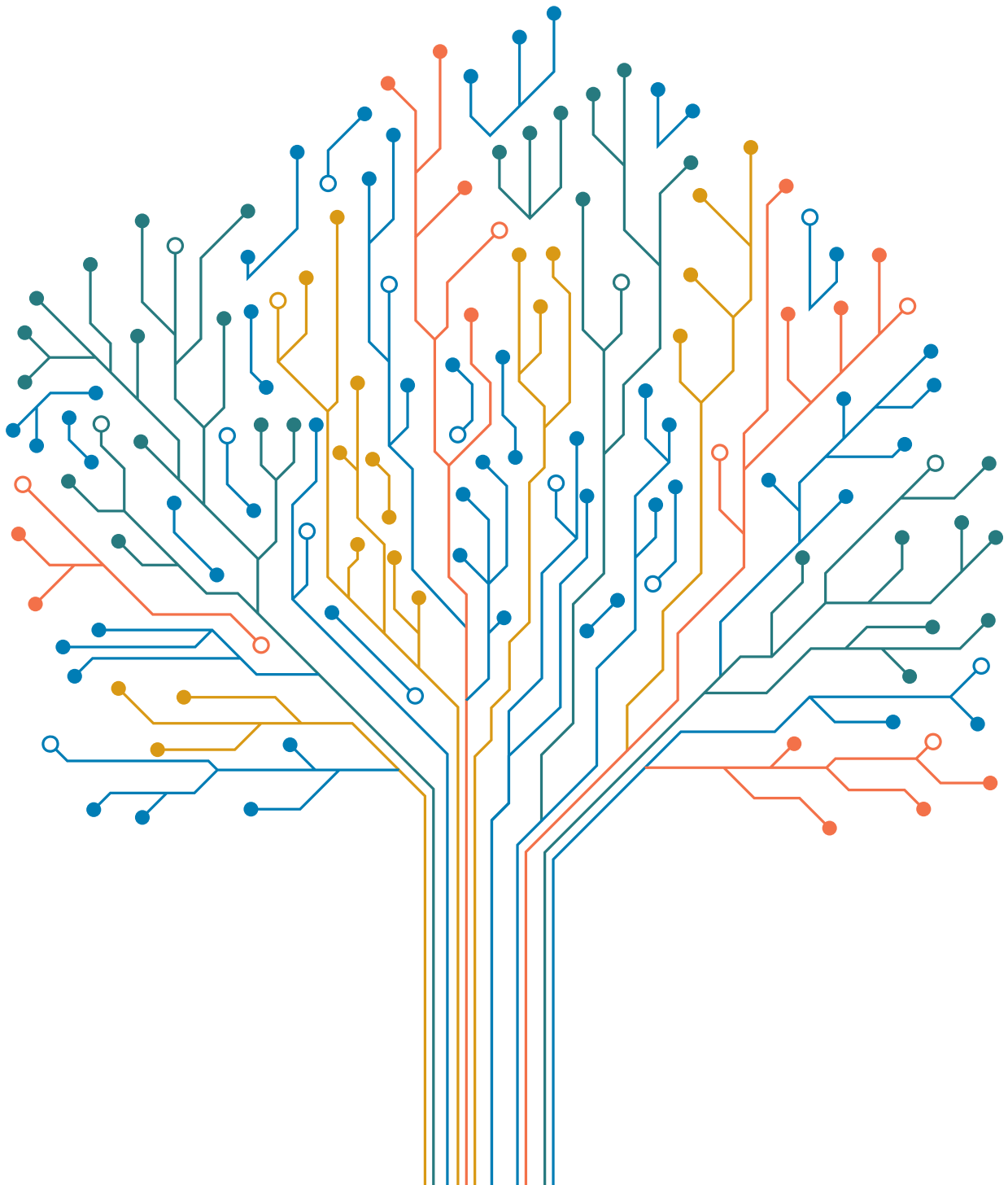

∴ Sustainability in action

Sustainability is the ability to take a long-term view and to consider the impact of what we do across the entire value chain. Sustainable development is a prerequisite for long-term progress for people, the planet and prosperity, in line with the sustainable development goals of the UN 2030 Agenda. The company's Sustainability Plan, in line with the Be Tomorrow - Leonardo 2030 strategic vision, translates this into concrete actions capable of generating shared and measurable long-term value.

Being sustainable brings advantages across the board: it catalyses talent, speeds up innovation processes and makes products more competitive. It helps to attract investors and improves access to credit, cost structure and process efficiency. It supports community development through the active involvement of stakeholders.

Its main strength is measurability. It has precise indicators linking economic and financial performance, the efficiency of processes, the professional development of people, and the impact on society and the environment. This provides a clear, verifiable reference point for the project, permitting assessment of its development over time.

Leonardo's environmental, social and governance (ESG) Key Performance Indicators (KPIs) are an essential prerequisite for all strategic, organisational, investment and business decisions: a way of working that Leonardo shares with the entire industrial ecosystem of which it is the driving force.

The sustainability goals adopted in Leonardo's business model represent essential elements for improving the company's competitiveness and generating lasting value for its stakeholders.

∴ ESG awards

- › At the top of **Transparency International's Defence Company Indices** on Anti-Corruption and Corporate Transparency.
- › Industry Leader, for the second time running, in the Aerospace and Defence sector of the **Dow Jones Sustainability Indices**, where it has featured since 2010.
- › **UN Global Compact Lead** and member of the **CFO task force**.
- › Included in **Bloomberg's Gender Equality** Index for the first time.
- › Included in the **CDP 2020** climate-A list for climate change and environmental impact rankings.

∴ CLIMATE A LIST

Leonardo is included in the Climate A List 2020 of the international non-profit organisation CDP, the highest category, including the world's leading companies - out of more than 9,500 analysed - in the fight against climate change. The list is compiled from information on environmental impact, risks and opportunities requested by more than 500 investors representing \$106 trillion in assets under management.

∴ DOW JONES SUSTAINABILITY INDICES

Leonardo ranked first in the Aerospace & Defence sector in the Dow Jones Sustainability Indices (DJSI), confirming its leadership for the second year in a row.

The result demonstrates that sustainability is an integral and guiding part of Leonardo's strategy, governance and vision to 2030. Leonardo has been included in the DJSI for 11 years in a row.

∴ TRANSPARENCY INTERNATIONAL INDEX

Leonardo has achieved the highest level in the Defence Companies Index on Anti-Corruption and Corporate Transparency (DCI) drawn up by Transparency International, joining A band, to which only two companies were admitted. Following analysis of the leading players in the sector worldwide, the non-governmental organisation Transparency International recognised and rewarded the measures implemented by Leonardo, from adoption of stricter anti-corruption policies to a significant increase in the level of transparency. The assessment is based solely on the analysis of public information accessible to all stakeholders, looking at 134 companies in the sector in 38 different countries.

∴ Priorities matrix

To identify strategic priorities (material issues), intelligence tools and big data analytics were used - following a data-driven approach - involving external and internal stakeholders through surveys. The data-driven analysis adopted enhances understanding of

stakeholder priorities by leveraging state-of-the-art methodologies to analyse vast amounts of publicly available data. The issues identified will allow risks and opportunities to be assessed and monitored over time in a more effective, timely and continuous manner.

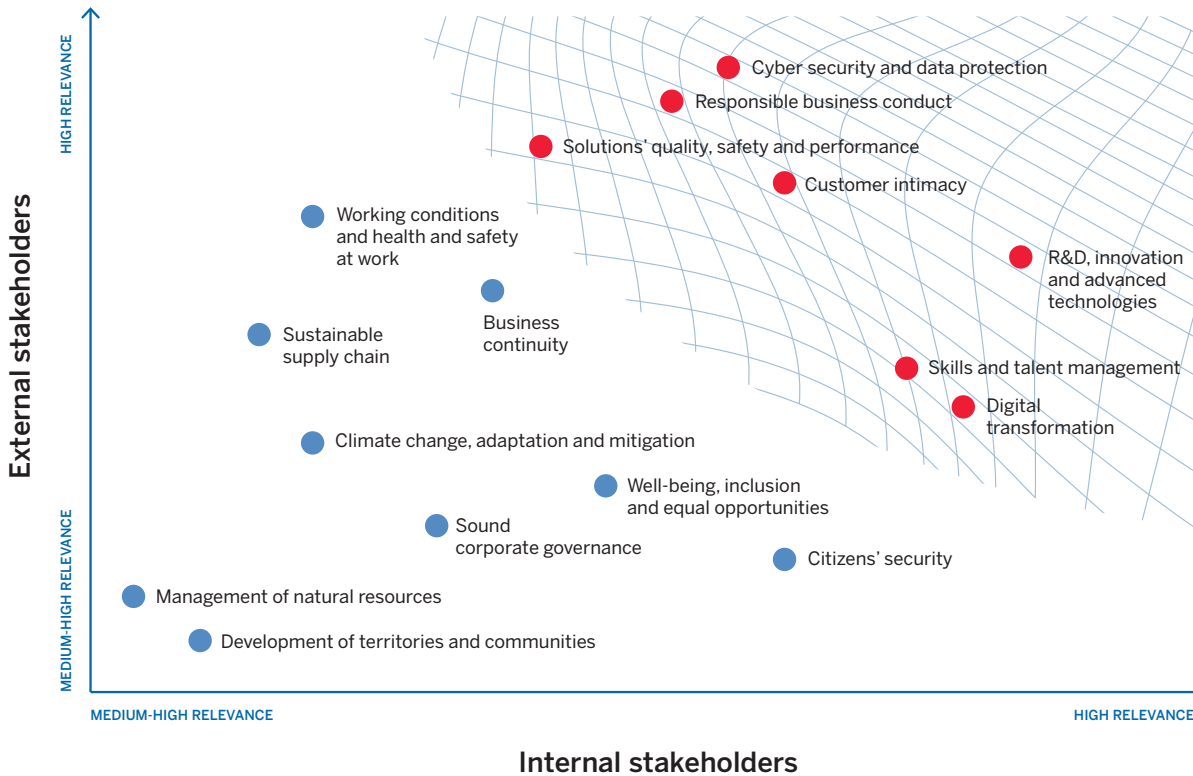

∴ PRINCIPLES OF GOVERNANCE

Effective control of business risks, the utmost transparency towards the market and integrity of decision-making processes in the interest of all stakeholders are the pillars of Leonardo's corporate governance, oriented towards protecting and maximising the company's long-term value.

26%
of share capital held by shareholders who are signatories to the Principles for Responsible Investment (PRI) promoted by the United Nations

42%
women on the Board of Directors

- ∴ Long-term **remuneration policy** for the CEO and top management is based on achievement of performance targets, also of a non-economic nature, linked to **ESG indicators**:
- Reducing CO₂ emissions
- Increased recruitment of women with STEM profiles

Measuring sustainability

Leonardo's Sustainability Plan covers the entire value chain: from research and technological innovation to operations and development of new solutions and new business models. Eight thematic areas (clusters) are identified in the Plan to accelerate the transition to a sustainable business model, in line with the objectives of the UN Agenda and the European Green Deal. Each cluster is structured into specific actions and projects, identified taking into account measurability, business and progress against the SDGs.

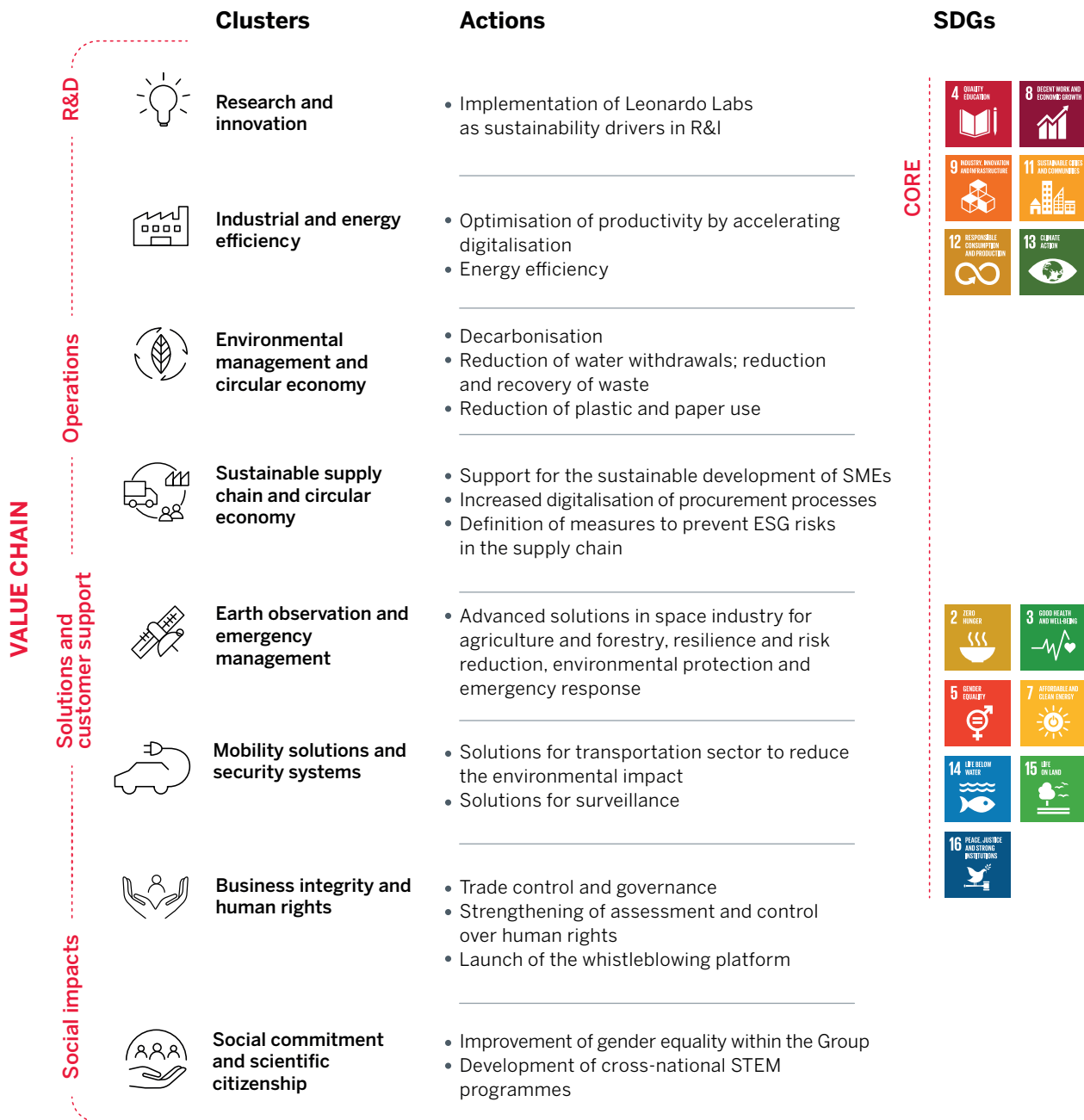

∴ The circular economy model

∴ OPTIMISE

- › Reducing materials through advanced design systems.
- › Applying the Product Life Cycle Management and Ecodesign approach.
- › Using composite materials to reduce weight, consumption and impact.

Reduction in fuel consumption by 10-15% and in emissions by 20% with the use of carbon fibre for aerostructures of aircrafts and helicopters. About 60% less of waste by using Additive Manufacturing for the construction of primary composite parts of the tiltrotor.

∴ EXTEND USEFUL LIFE

- › Optimising maintenance cycle.
- › Replacing only components that reach end of life.
- › Upgrading software to extend the life of hardware components.

Aircraft structures capable of maintaining a level of useful life greater than 20 years of operation.

∴ SHARE AND DEMATERIALISE

- › Selling flight hours instead of products.
- › Virtual product testing.
- › Virtual training systems.











More than 28,770 tons of CO₂ avoided through the use of virtual training systems in 2020. Reduction in IT energy consumption thanks to the rationalisation and consolidation from two data centres to two target data centres, increasing reliability and security.

∴ RECYCLE/REUSE

- › Using recyclable metal materials.
- › Regeneration of used components.
- › Recycling of auxiliary materials, packaging, assembly platforms and metal equipment.
- › Buy-back of used helicopters.

More than 70% of aircraft and helicopters in circulation composed of recyclable metal parts. 52% of waste produced was recovered in 2020. Over 1,500 kg of ferrous material put back into use thanks to the disposal of 4,000 kg of WEEE (Waste of Electrical and Electronic Equipment) through a social impact project in 2020.

∴ Sustainability goals

Pillar	Scope	Objectives	Target year	Impacts	
Governance	Promote a responsible business model	Issue of a Trade Compliance Guideline including Human Rights Impact Assessment (HRIA) and development of country risk assessment tools for Leonardo SpA	2021	Target 16.5, 16.6 	
		Extending Trade Compliance Directive to the Group	2022		
		Renewal/maintenance of the ISO 37001:2016 "Anti-Bribery Management System" certification standard	2023		
		Expanding the business compliance training to other types of third parties (distributors/resellers), making it a mandatory prerequisite for the completion of the engagement	2022		
		Training in whistleblowing	2021		
People	Attract and promote talent	More than 100 training hours per employee in the period 2018-2022	2022	Target 4.3, 4.4 Target 5.1, 5.5, 5.b  	
		Under 30s equal to at least 40% of total new hires	2022		
	Promote an inclusive environment	Women equal to at least 32% of total new hires	2022		
		Women equal to 30% of total new hires in STEM areas	2025		
		20% female representation at management levels	2025		
Planet	Reduce energy consumption and CO ₂ emissions	10% reduction in electricity consumption*	2025	Target 8.4 Target 9.4 Target 12.2, 12.5 Target 13.1, 13.3  	
		4% reduction in Scope I + Scope II emissions (location-based)*	2025		
		40% reduction in Scope I + Scope II emissions (market-based)**	2030		
	Reduce environmental impacts	10% reduction in water withdrawals*	2025		 
		10% reduction in the amount of waste produced*	2025		
Prosperity	Develop the supply chain	Implement supply chain development programmes and medium/long-term partnerships, focused on SMEs, to improve business sustainability	2023	Target 8.2, 8.3 Target 9.4, 9.5 Target 12.2, 12.5 Target 13.1    	
		Manage more than 75% of the value of orders placed by Leonardo Divisions with digital collaboration platforms***	2022		
		Raise awareness of/deliver training on SDGs and supporting tools for reporting to more than 80% of key suppliers (over 500 suppliers)	2023		
		100% of LEAP2020 partners with set targets and plans on green energy, CO ₂ emission reduction, waste recycling, water consumption	2023		
	Strengthen digitalisation and processing capacity	Increasing computing power by 40% per capita****	2025		
		Increasing storage capacity by 40% per capita****	2025		







* Calculated in relation to revenues. 2019 year baseline.

** Reduction in absolute value. 2019 year baseline.

*** Includes recurring suppliers. Leonardo DRS is not included in the scope.

**** Calculated as the number of flops (floating point operations per second) and bytes in relation to employees in Italy. 2020 year baseline.

2017-2020 ESG performance

Areas	Performance in the period 2017-2020	Impacts
Attract and promote talent	<ul style="list-style-type: none"> Over 6,400 people under 30 hired Employees under 30 from 8.2% to 10.3% of workforce (+1,455 employees under 30) Over 3,200 training opportunities activated with the educational system 	     
Promote an inclusive environment	<ul style="list-style-type: none"> Over 3,400 women hired Increased women managers from 15.1% to 17.3% of total managers and middle managers (+269 women managers among employees) 	
Extend the adoption of certified environmental, health and safety management systems	<ul style="list-style-type: none"> 75% of employees work in sites with certified health and safety management system (56% in 2017) 76% of employees work in sites with certified environmental management systems (66% in 2017) 	
Reduce energy consumption and CO ₂ emissions	<ul style="list-style-type: none"> 16% reduction in intensity of energy consumption 1% reduction in Scope I and II CO₂ emissions intensity (location-based) 	
Reduce environmental impacts	<ul style="list-style-type: none"> 7% reduction in intensity of waste produced About 73,000 tons of waste recovered 23% reduction of intensity of water withdrawals 	

SDG-aligned investments

- Over the 2021-2022 two-year period, Leonardo will invest an average of €600-700 million annually*
- Leonardo is committed to keeping about **50% of its investments aligned with the SDGs**
- The initiatives mainly impact SDG 9 "Enterprise, Innovation and Infrastructure", SDG 8 "Decent Work and Economic Growth", and SDG 11 "Sustainable Cities and Communities"

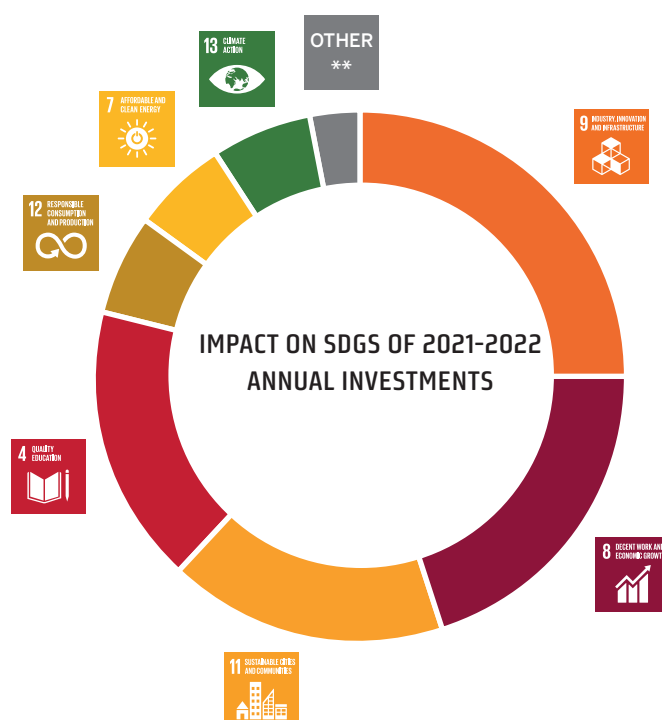

*Includes gross capitalised R&D, Investment in tangible assets, equipment and other intangible assets

**Includes SDG 6, SDG 14 and SDG 15

For more information, see:

